

100 kPa On-Chip Temperature Compensated & Calibrated Silicon Pressure Sensors

The MPX2102/MPXV2102G series device is a silicon piezoresistive pressure sensor providing a highly accurate and linear voltage output directly proportional to the applied pressure. The sensor is a single, monolithic silicon diaphragm with the strain gauge and a thin-film resistor network integrated on-chip. The chip is laser trimmed for precise span and offset calibration and temperature compensation.

Features

- Temperature Compensated Over 0°C to +85°C
- Easy-to-Use Chip Carrier Package Options
- Available in Absolute, Differential and Gauge Configurations
- Ratiometric to Supply Voltage

Application Examples

- Pump/Motor Controllers
- Robotics
- Level Indicators
- Medical Diagnostics
- Pressure Switching
- Barometers
- Altimeters

MPX2102 MPXV2102G SERIES

0 TO 100 kPa (0 TO 14.5 psi)
40 mV FULL SCALE SPAN
(TYPICAL)

SMALL OUTLINE PACKAGES

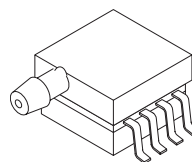

MPX2102GP
CASE 1369-01

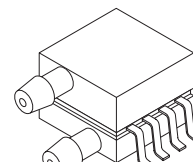

MPXV2102DP
CASE 1351-01

ORDERING INFORMATION

Device Type	Options	Case No.	MPX Series Order No.	Packing Options	Device Marking
SMALL OUTLINE PACKAGE (MPXV2102G SERIES)					
Ported Elements	Gauge, Side Port, SMT	1369	MPXV2102GP	Trays	MPXV2102G
	Differential, Dual Port, SMT	1351	MPXV2102DP	Trays	MPXV2102G
UNIBODY PACKAGE (MPX2102 SERIES)					
Basic Element	Absolute, Differential	344	MPX2102A MPX2102D	—	MPX2102A MPX2102D
Ported Elements	Differential, Dual Port	344C	MPX2102DP	—	MPX2102DP
	Absolute, Gauge	344B	MPX2102AP MPX2102GP	—	MPX2102AP MPX2102GP
	Absolute, Gauge Axial	344F	MPX2102ASX MPX2102GSX	—	MPX2102A MPX2102D
	Gauge, Vacuum	344D	MPX2102GVP	—	MPX2102GVP

SMALL OUTLINE PACKAGE PIN NUMBERS

1	GND ⁽¹⁾	5	N/C
2	+V _{OUT}	6	N/C
3	V _S	7	N/C
4	-V _{OUT}	8	N/C

1. Pin 1 in noted by the notch in the lead.

UNIBODY PACKAGE PIN NUMBERS

1	GND ⁽¹⁾	3	V _S
2	+V _{OUT}	4	-V _{OUT}

1. Pin 1 in noted by the notch in the lead.

UNIBODY PACKAGES

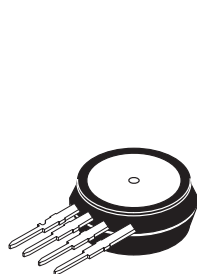

MPX2102A/D
CASE 344-15

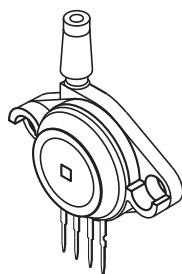

MPX2102AP/GP
CASE 344B-01

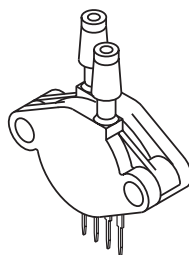

MPX2102DP
CASE 344C-01

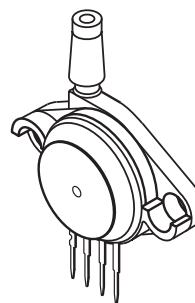

MPX2102GVP
CASE 344D-01

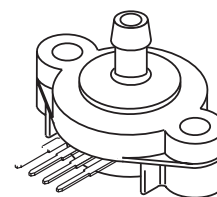

MPX2102ASX/GSX
CASE 344F-01

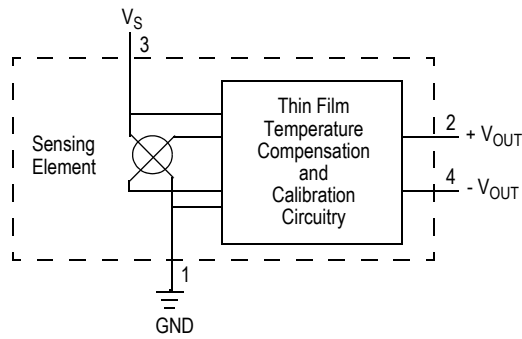

Figure 1. Temperature Compensated Pressure Sensor Schematic

VOLTAGE OUTPUT VS. APPLIED DIFFERENTIAL PRESSURE

The differential voltage output of the sensor is directly proportional to the differential pressure applied.

The absolute sensor has a built-in reference vacuum. The output voltage will decrease as vacuum, relative to ambient, is drawn on the pressure (P1) side.

The output voltage of the differential or gauge sensor increases with increasing pressure applied to the pressure

(P1) side relative to the vacuum (P2) side. Similarly, output voltage increases as increasing vacuum is applied to the vacuum (P2) side relative to the pressure (P1) side.

Figure 1 illustrates a block diagram of the internal circuitry on the stand-alone pressure sensor chip.

Table 1. Maximum Ratings⁽¹⁾

Rating	Symbol	Value	Unit
Maximum Pressure (P1 > P2)	P_{MAX}	400	kPa
Storage Temperature	T_{STG}	-40 to +125	°C
Operating Temperature	T_A	-40 to +125	°C

1. Exposure beyond the specified limits may cause permanent damage or degradation to the device.

Table 2. Operating Characteristics ($V_S = 10 V_{DC}$, $T_A = 25^\circ C$ unless otherwise noted, $P1 > P2$)

Characteristic	Symbol	Min	Typ	Max	Units	
Differential Pressure Range ⁽¹⁾	P_{OP}	0	—	100	kPa	
Supply Voltage ⁽²⁾	V_S	—	10	16	V_{DC}	
Supply Current	I_O	—	6.0	—	mAdc	
Full Scale Span ⁽³⁾	V_{FSS}	38.5	40	41.5	mV	
Offset ⁽⁴⁾	MPX2102D Series MPX2102A Series	V_{OFF}	-1.0 -2.0	— —	1.0 2.0	mV
Sensitivity		$\Delta V/\Delta P$	—	0.4	—	mV/kPa
Linearity ⁽⁵⁾	MPX2102D Series MPX2102A Series	—	-0.6 -1.0	— —	0.4 1.0	% V_{FSS}
Pressure Hysteresis ⁽⁵⁾ (0 to 100 kPa)		—	—	± 0.1	—	% V_{FSS}
Temperature Hysteresis ⁽⁵⁾ (-40°C to +125°C)		—	—	± 0.5	—	% V_{FSS}
Temperature Coefficient of Full Scale Span ⁽⁵⁾		TCV_{FSS}	-2.0	—	2.0	% V_{FSS}
Temperature Coefficient of Offset ⁽⁵⁾		TCV_{OFF}	-1.0	—	1.0	mV
Input Impedance		Z_{IN}	1000	—	2500	W
Output Impedance		Z_{OUT}	1400	—	3000	W
Response Time ⁽⁶⁾ (10% to 90%)		t_R	—	1.0	—	ms
Warm-Up Time		—	—	20	—	ms
Offset Stability ⁽⁷⁾		—	—	± 0.5	—	% V_{FSS}

- 1.0 kPa (kiloPascal) equals 0.145 psi.
- Device is ratiometric within this specified excitation range. Operating the device above the specified excitation range may induce additional error due to device self-heating.
- Full Scale Span (V_{FSS}) is defined as the algebraic difference between the output voltage at full rated pressure and the output voltage at the minimum related pressure.
- Offset (V_{OFF}) is defined as the output voltage at the minimum rated pressure.
- Accuracy (error budget) consists of the following:
 - Linearity: Output deviation from a straight line relationship with pressure, using end point method, over the specified pressure range.
 - Temperature Hysteresis: Output deviation at any temperature within the operating temperature range, after the temperature is cycled to and from the minimum or maximum operating temperature points, with zero differential pressure applied.
 - Pressure Hysteresis: Output deviation at any pressure with the specified range, when this pressure is cycled to and from the minimum or maximum rated pressure at 25°C.
 - TcSpan: Output deviation at full rated pressure over the temperature range of 0 to 85°C, relative to 25°C.
 - TcOffset: Output deviation with minimum rated pressure applied, over the temperature range of 0 to 85°C, relative to 25°C.
- Response Time is defined as the time from the incremental change in the output to go from 10% to 90% of its final value when subjected to a specified step change in pressure.
- Offset stability is the product's output deviation when subjected to 1000 hours of Pulsed Pressure, Temperature Cycling with Bias Test.

LINEARITY

Linearity refers to how well a transducer's output follows the equation: $V_{OUT} = V_{OFF} + \text{sensitivity} \times P$ over the operating pressure range. There are two basic methods for calculating nonlinearity: (1) end point straight line fit (see Figure 2) or (2) a least squares best line fit. While a least squares fit gives the "best case" linearity error (lower numerical value), the calculations required are burdensome.

Conversely, an end point fit will give the "worst case" error (often more desirable in error budget calculations) and the calculations are more straightforward for the user. Freescale's specified pressure sensor linearities are based on the end point straight line method measured at the midrange pressure.

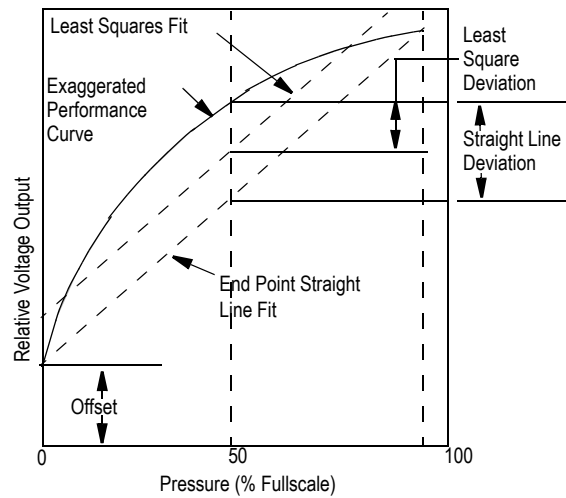

Figure 2. Linearity Specification Comparison

ON-CHIP TEMPERATURE COMPENSATION AND CALIBRATION

Figure 3 shows the output characteristics of the MPX2102/MPXV2102G series at 25°C. The output is directly proportional to the differential pressure and is essentially a straight line.

The effects of temperature on Full Scale Span and Offset are very small and are shown under Operating Characteristics.

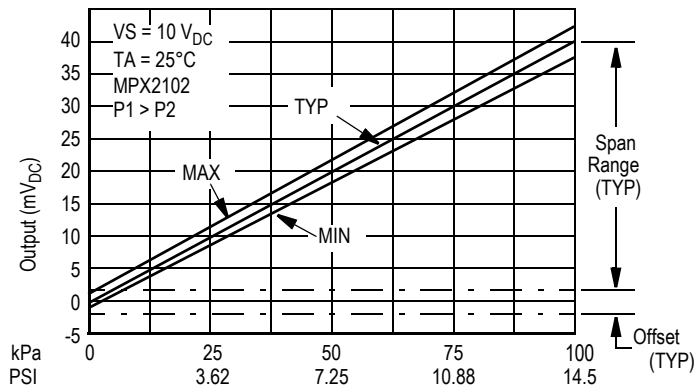

Figure 3. Output vs. Pressure Differential

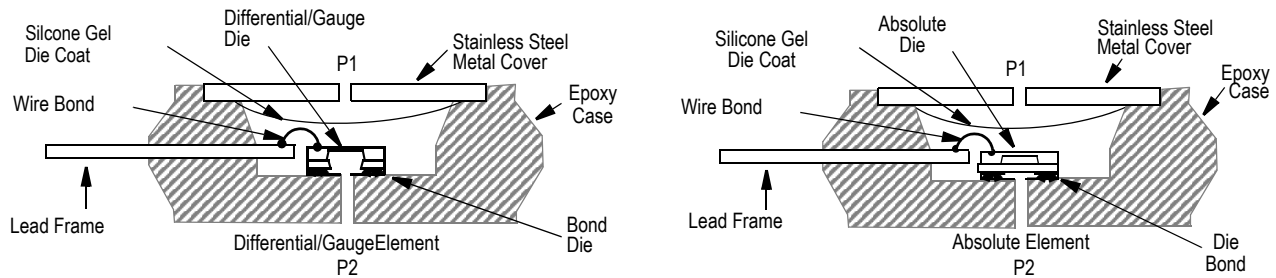

Figure 4. Cross Sectional Diagrams (Not to Scale)

Figure 4 illustrates the absolute sensing configuration (right) and the differential or gauge configuration in the basic chip carrier (Case 344). A silicone gel isolates the die surface and wire bonds from the environment, while allowing the pressure signal to be transmitted to the silicon diaphragm.

The MPX2102/MPXV2102G series pressure sensor operating characteristics and internal reliability and

qualification tests are based on use of dry air as the pressure media. Media other than dry air may have adverse effects on sensor performance and long term reliability. Contact the factory for information regarding media compatibility in your application.

MPX2102

PRESSURE (P1)/VACUUM (P2) SIDE IDENTIFICATION TABLE

Freescale designates the two sides of the pressure sensor as the Pressure (P1) side and the Vacuum (P2) side. The Pressure (P1) side is the side containing the silicone gel which isolates the die. The differential or gauge sensor is designed to operate with positive differential pressure applied, $P1 > P2$. The absolute sensor is designed for vacuum applied to P1 side.

The Pressure (P1) side may be identified by using [Table 3](#).

Table 3. Pressure (P1) Side Delineation

Part Number		Case Type	Pressure (P1) Side Identifier
MPX2102A	MPX2102D	344	Stainless Steep Cap
MPX2102DP		344C	Side with Part Marking
MPX2102AP	MPX2102GP	344B	Side with Port Attached
MPX2102GVP		344D	Stainless Steep Cap
MPX2102ASX	MPX2102GSX	344F	Side with Port Marking
MPX2102GP		1369	Side with Port Attached
MPX2102DP		1351	Side with Part Marking

PACKAGE DIMENSIONS

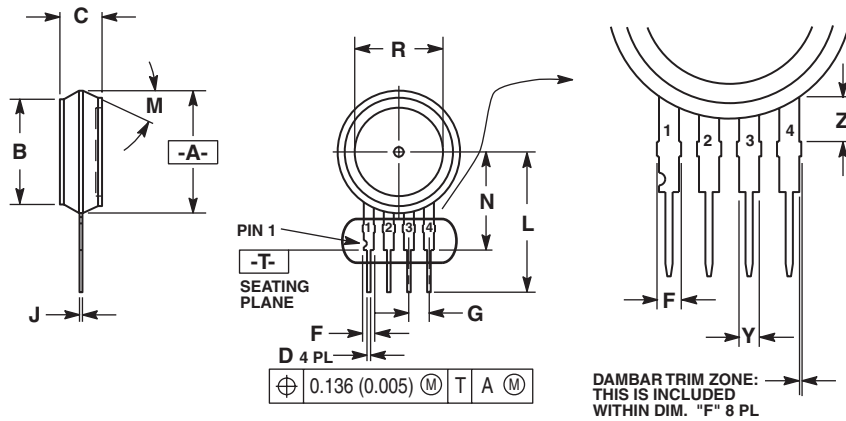

- NOTES:
1. DIMENSIONING AND TOLERANCING PER ASME Y14.5M, 1994.
 2. CONTROLLING DIMENSION: INCH.
 3. DIMENSION -A- IS INCLUSIVE OF THE MOLD STOP RING. MOLD STOP RING NOT TO EXCEED 16.00 (0.630).

DIM	INCHES		MILLIMETERS	
	MIN	MAX	MIN	MAX
A	0.595	0.630	15.11	16.00
B	0.514	0.534	13.06	13.56
C	0.200	0.220	5.08	5.59
D	0.016	0.020	0.41	0.51
F	0.048	0.064	1.22	1.63
G	0.100 BSC		2.54 BSC	
J	0.014	0.016	0.36	0.40
L	0.695	0.725	17.65	18.42
M	30° NOM		30° NOM	
N	0.475	0.495	12.07	12.57
R	0.430	0.450	10.92	11.43
Y	0.048	0.052	1.22	1.32
Z	0.106	0.118	2.68	3.00

- STYLE 1:
 PIN 1. GROUND
 2. + OUTPUT
 3. + SUPPLY
 4. - OUTPUT
- STYLE 2:
 PIN 1. V_{CC}
 2. - SUPPLY
 3. + SUPPLY
 4. GROUND
- STYLE 3:
 PIN 1. GND
 2. -VOUT
 3. VS
 4. +VOUT

CASE 344-15 ISSUE AA UNIBODY PACKAGE

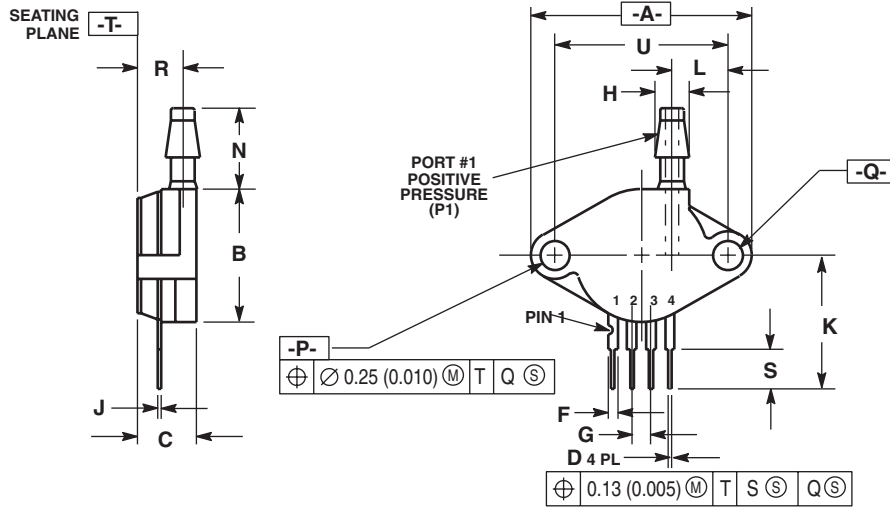

- NOTES:
1. DIMENSIONING AND TOLERANCING PER ANSI Y14.5M, 1982.
 2. CONTROLLING DIMENSION: INCH.

DIM	INCHES		MILLIMETERS	
	MIN	MAX	MIN	MAX
A	1.145	1.175	29.08	29.85
B	0.685	0.715	17.40	18.16
C	0.305	0.325	7.75	8.26
D	0.016	0.020	0.41	0.51
F	0.048	0.064	1.22	1.63
G	0.100 BSC		2.54 BSC	
H	0.182	0.194	4.62	4.93
J	0.014	0.016	0.36	0.41
K	0.695	0.725	17.65	18.42
L	0.290	0.300	7.37	7.62
N	0.420	0.440	10.67	11.18
P	0.153	0.159	3.89	4.04
Q	0.153	0.159	3.89	4.04
R	0.230	0.250	5.84	6.35
S	0.220	0.240	5.59	6.10
U	0.910 BSC		23.11 BSC	

- STYLE 1:
 PIN 1. GROUND
 2. + OUTPUT
 3. + SUPPLY
 4. - OUTPUT

CASE 344B-01 ISSUE B UNIBODY PACKAGE

PACKAGE DIMENSIONS

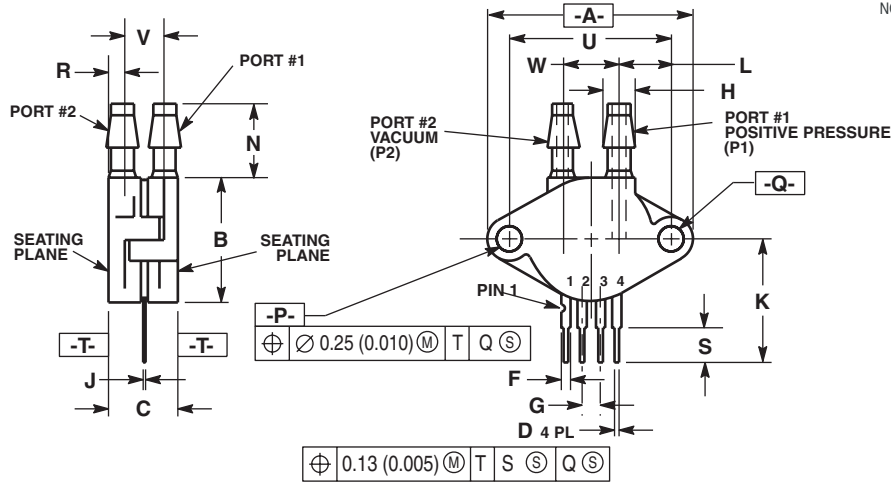

- NOTES:
 1. DIMENSIONING AND TOLERANCING PER ANSI Y14.5M, 1982.
 2. CONTROLLING DIMENSION: INCH.

DIM	INCHES		MILLIMETERS	
	MIN	MAX	MIN	MAX
A	1.145	1.175	29.08	29.85
B	0.685	0.715	17.40	18.16
C	0.405	0.435	10.29	11.05
D	0.016	0.020	0.41	0.51
F	0.048	0.064	1.22	1.63
G	0.100 BSC		2.54 BSC	
H	0.182	0.194	4.62	4.93
J	0.014	0.016	0.36	0.41
K	0.695	0.725	17.65	18.42
L	0.290	0.300	7.37	7.62
N	0.420	0.440	10.67	11.18
P	0.153	0.159	3.89	4.04
Q	0.153	0.159	3.89	4.04
R	0.063	0.083	1.60	2.11
S	0.220	0.240	5.59	6.10
U	0.910 BSC		23.11 BSC	
V	0.248	0.278	6.30	7.06
W	0.310	0.330	7.87	8.38

- STYLE 1:
 PIN 1. GROUND
 2. + OUTPUT
 3. + SUPPLY
 4. - OUTPUT

CASE 344C-01 ISSUE B UNIBODY PACKAGE

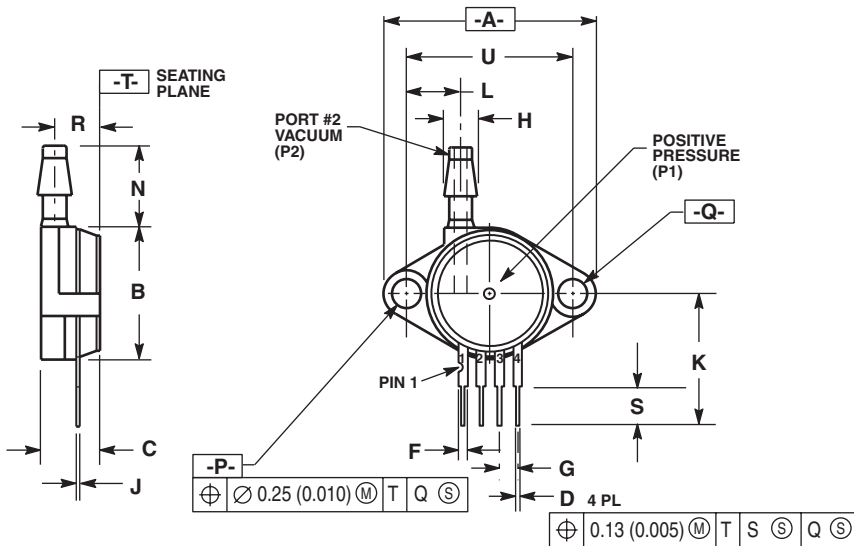

- NOTES:
 1. DIMENSIONING AND TOLERANCING PER ASME Y14.5M, 1994.
 2. CONTROLLING DIMENSION: INCH.

DIM	INCHES		MILLIMETERS	
	MIN	MAX	MIN	MAX
A	1.145	1.175	29.08	29.85
B	0.685	0.715	17.40	18.16
C	0.305	0.325	7.75	8.26
D	0.016	0.020	0.41	0.51
F	0.048	0.064	1.22	1.63
G	0.100 BSC		2.54 BSC	
H	0.182	0.194	4.62	4.93
J	0.014	0.016	0.36	0.41
K	0.695	0.725	17.65	18.42
L	0.290	0.300	7.37	7.62
N	0.420	0.440	10.67	11.18
P	0.153	0.159	3.89	4.04
Q	0.153	0.158	3.89	4.04
R	0.230	0.250	5.84	6.35
S	0.220	0.240	5.59	6.10
U	0.910 BSC		23.11 BSC	

- STYLE 1:
 PIN 1. GROUND
 2. + OUTPUT
 3. + SUPPLY
 4. - OUTPUT

CASE 344D-01 ISSUE B UNIBODY PACKAGE

PACKAGE DIMENSIONS

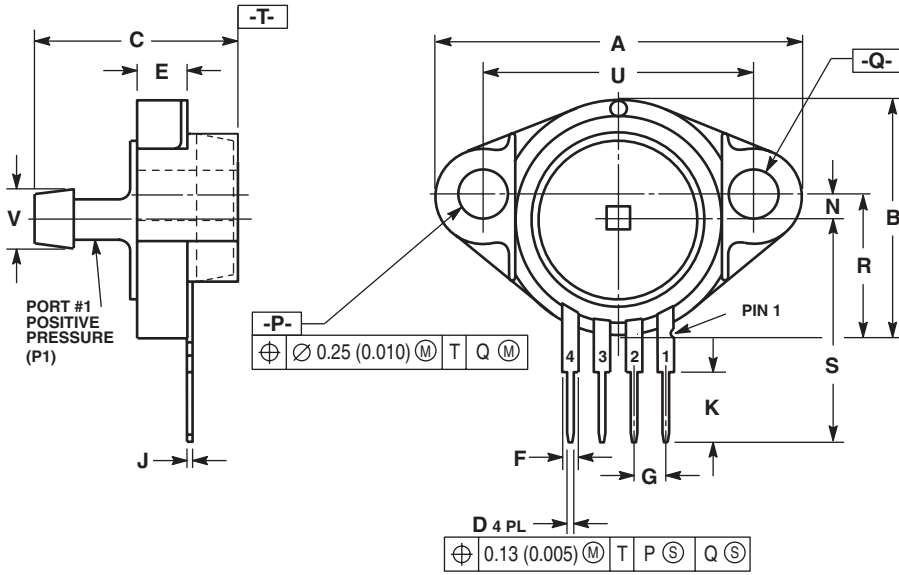

NOTES:

1. DIMENSIONING AND TOLERANCING PER ANSI Y14.5M, 1982.
2. CONTROLLING DIMENSION: INCH.

DIM	INCHES		MILLIMETERS	
	MIN	MAX	MIN	MAX
A	1.080	1.120	27.43	28.45
B	0.740	0.760	18.80	19.30
C	0.630	0.650	16.00	16.51
D	0.016	0.020	0.41	0.51
E	0.160	0.180	4.06	4.57
F	0.048	0.064	1.22	1.63
G	0.100 BSC		2.54 BSC	
J	0.014	0.016	0.36	0.41
K	0.220	0.240	5.59	6.10
N	0.070	0.080	1.78	2.03
P	0.150	0.160	3.81	4.06
Q	0.150	0.160	3.81	4.06
R	0.440	0.460	11.18	11.68
S	0.695	0.725	17.65	18.42
U	0.840	0.860	21.34	21.84
V	0.182	0.194	4.62	4.92

STYLE 1:

- PIN 1: GROUND
- 2: V (+) OUT
- 3: V SUPPLY
- 4: V (-) OUT

**CASE 344F-01
ISSUE B
UNIBODY PACKAGE**

PACKAGE DIMENSIONS

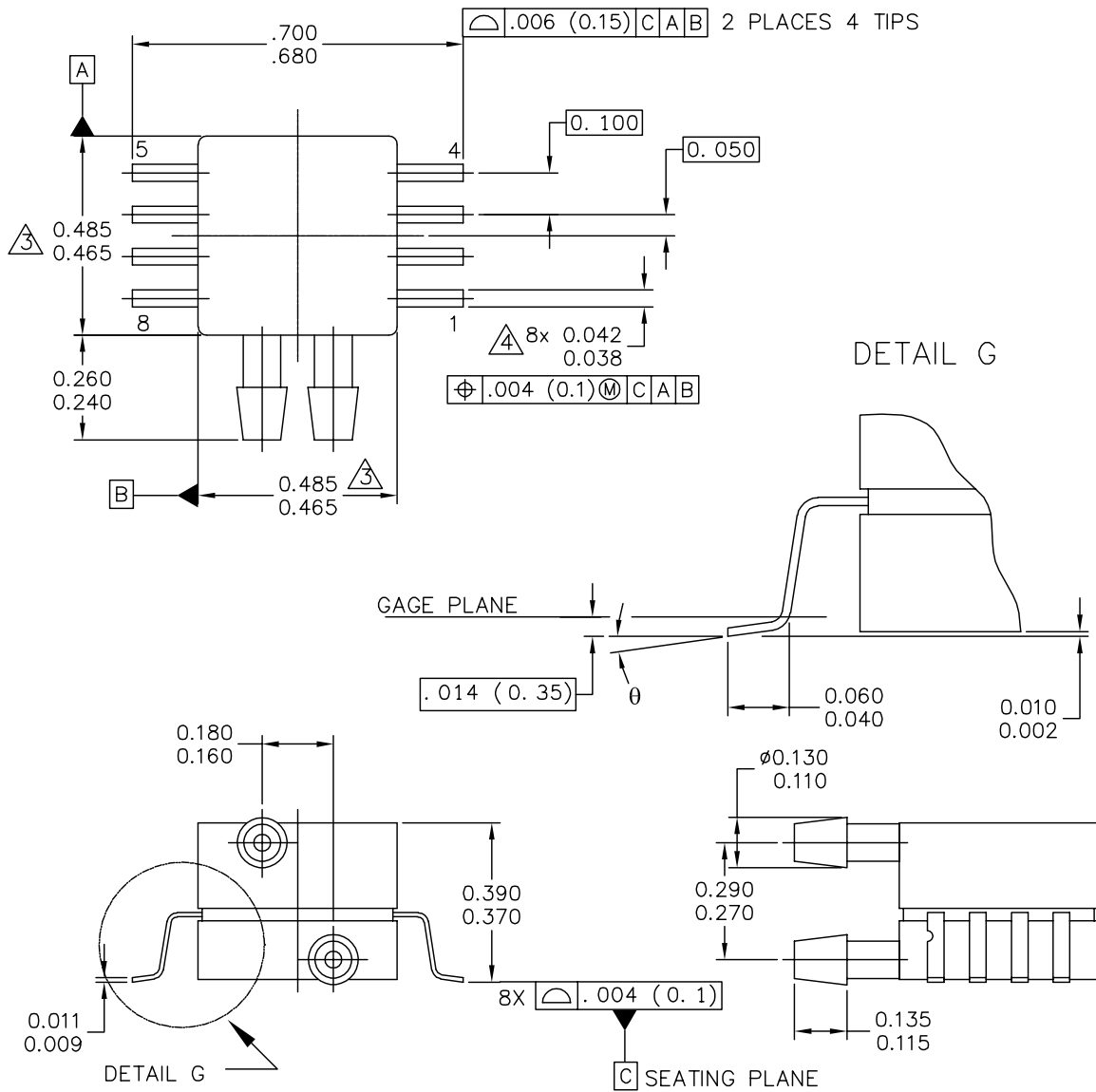

© FREESCALE SEMICONDUCTOR, INC. ALL RIGHTS RESERVED.	MECHANICAL OUTLINE	PRINT VERSION NOT TO SCALE
TITLE: 8 LD SNSR, DUAL PORT	DOCUMENT NO: 98ASA99255D	REV: A
	CASE NUMBER: 1351-01	27 JUL 2005
	STANDARD: NON-JEDEC	

PAGE 1 OF 2

**CASE 1351-01
ISSUE A
SMALL OUTLINE PACKAGE**

MPX2102

PACKAGE DIMENSIONS

NOTES:

1. CONTROLLING DIMENSION: INCH
2. INTERPRET DIMENSIONS AND TOLERANCES PER ASME Y14.5M-1994.
3. DIMENSIONS DO NOT INCLUDE MOLD FLASH OR PROTRUSIONS.
MOLD FLASH AND PROTRUSIONS SHALL NOT EXCEED .006 PER SIDE.
4. DIMENSION DOES NOT INCLUDE DAMBAR PROTRUSION. ALLOWABLE DAMBAR PROTRUSION SHALL BE .008 MAXIMUM.

STYLE 1:

PIN 1: GND
 PIN 2: +Vout
 PIN 3: Vs
 PIN 4: -Vout
 PIN 5: N/C
 PIN 6: N/C
 PIN 7: N/C
 PIN 8: N/C

STYLE 2:

PIN 1: N/C
 PIN 2: Vs
 PIN 3: GND
 PIN 4: Vout
 PIN 5: N/C
 PIN 6: N/C
 PIN 7: N/C
 PIN 8: N/C

© FREESCALE SEMICONDUCTOR, INC. ALL RIGHTS RESERVED.	MECHANICAL OUTLINE	PRINT VERSION NOT TO SCALE
TITLE: 8 LD SNSR, DUAL PORT	DOCUMENT NO: 98ASA99255D CASE NUMBER: 1351-01 STANDARD: NON-JEDEC	REV: A 27 JUL 2005

PAGE 2 OF 2

CASE 1351-01
ISSUE A
SMALL OUTLINE PACKAGE

PACKAGE DIMENSIONS

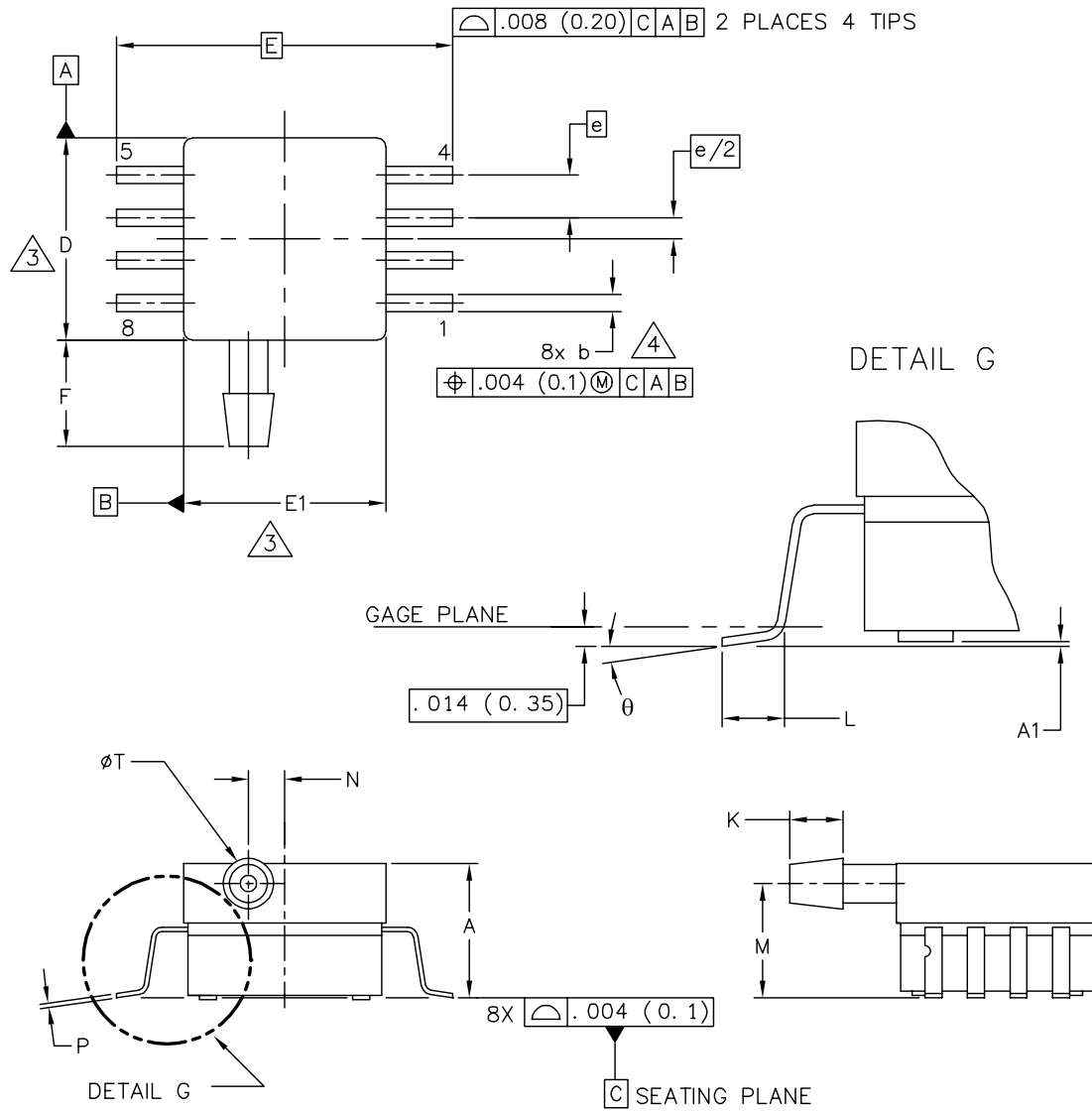

© FREESCALE SEMICONDUCTOR, INC. ALL RIGHTS RESERVED.	MECHANICAL OUTLINE	PRINT VERSION NOT TO SCALE	
TITLE: 8 LD SOP, SIDE PORT	DOCUMENT NO: 98ASA99303D	REV: B	
	CASE NUMBER: 1369-01	24 MAY 2005	
	STANDARD: NON-JEDEC		

PAGE 1 OF 2

**CASE 1369-01
ISSUE B
SMALL OUTLINE PACKAGE**

MPX2102

PACKAGE DIMENSIONS

NOTES:

1. CONTROLLING DIMENSION: INCH
 2. INTERPRET DIMENSIONS AND TOLERANCES PER ASME Y14.5M-1994.
- ③ DIMENSIONS DO NOT INCLUDE MOLD FLASH OR PROTRUSIONS.
MOLD FLASH AND PROTRUSIONS SHALL NOT EXCEED .006 (0.152) PER SIDE.
- ④ DIMENSION DOES NOT INCLUDE DAMBAR PROTRUSION. ALLOWABLE DAMBAR PROTRUSION SHALL BE .008 (0.203) MAXIMUM.

DIM	INCHES		MILLIMETERS		DIM	INCHES		MILLIMETERS	
	MIN	MAX	MIN	MAX		MIN	MAX	MIN	MAX
A	.300	.330	7.11	7.62	θ	0°	7°	0°	7°
A1	.002	.010	0.05	0.25	-	---	---	---	---
b	.038	.042	0.96	1.07	-	---	---	---	---
D	.465	.485	11.81	12.32	-	---	---	---	---
E	.717 BSC		18.21 BSC		-	---	---	---	---
E1	.465	.485	11.81	12.32	-	---	---	---	---
e	.100 BSC		2.54 BSC		-	---	---	---	---
F	.245	.255	6.22	6.47	-	---	---	---	---
K	.120	.130	3.05	3.30	-	---	---	---	---
L	.061	.071	1.55	1.80	-	---	---	---	---
M	.270	.290	6.86	7.36	-	---	---	---	---
N	.080	.090	2.03	2.28	-	---	---	---	---
P	.009	.011	0.23	0.28	-	---	---	---	---
T	.115	.125	2.92	3.17	-	---	---	---	---
© FREESCALE SEMICONDUCTOR, INC. ALL RIGHTS RESERVED.			MECHANICAL OUTLINE			PRINT VERSION NOT TO SCALE			
TITLE: 8 LD SOP, SIDE PORT					DOCUMENT NO: 98ASA99303D			REV: B	
					CASE NUMBER: 1369-01			24 MAY 2005	
					STANDARD: NON-JEDEC				

PAGE 2 OF 2

**CASE 1369-01
ISSUE B
SMALL OUTLINE PACKAGE**

NOTES

How to Reach Us:

Home Page:

www.freescale.com

Web Support:

<http://www.freescale.com/support>

USA/Europe or Locations Not Listed:

Freescale Semiconductor, Inc.
Technical Information Center, EL516
2100 East Elliot Road
Tempe, Arizona 85284
+1-800-521-6274 or +1-480-768-2130
www.freescale.com/support

Europe, Middle East, and Africa:

Freescale Halbleiter Deutschland GmbH
Technical Information Center
Schatzbogen 7
81829 Muenchen, Germany
+44 1296 380 456 (English)
+46 8 52200080 (English)
+49 89 92103 559 (German)
+33 1 69 35 48 48 (French)
www.freescale.com/support

Japan:

Freescale Semiconductor Japan Ltd.
Headquarters
ARCO Tower 15F
1-8-1, Shimo-Meguro, Meguro-ku,
Tokyo 153-0064
Japan
0120 191014 or +81 3 5437 9125
support.japan@freescale.com

Asia/Pacific:

Freescale Semiconductor Hong Kong Ltd.
Technical Information Center
2 Dai King Street
Tai Po Industrial Estate
Tai Po, N.T., Hong Kong
+800 2666 8080
support.asia@freescale.com

For Literature Requests Only:

Freescale Semiconductor Literature Distribution Center
P.O. Box 5405
Denver, Colorado 80217
1-800-441-2447 or 303-675-2140
Fax: 303-675-2150
LDCForFreescaleSemiconductor@hibbertgroup.com

Information in this document is provided solely to enable system and software implementers to use Freescale Semiconductor products. There are no express or implied copyright licenses granted hereunder to design or fabricate any integrated circuits or integrated circuits based on the information in this document.

Freescale Semiconductor reserves the right to make changes without further notice to any products herein. Freescale Semiconductor makes no warranty, representation or guarantee regarding the suitability of its products for any particular purpose, nor does Freescale Semiconductor assume any liability arising out of the application or use of any product or circuit, and specifically disclaims any and all liability, including without limitation consequential or incidental damages. "Typical" parameters that may be provided in Freescale Semiconductor data sheets and/or specifications can and do vary in different applications and actual performance may vary over time. All operating parameters, including "Typicals", must be validated for each customer application by customer's technical experts. Freescale Semiconductor does not convey any license under its patent rights nor the rights of others. Freescale Semiconductor products are not designed, intended, or authorized for use as components in systems intended for surgical implant into the body, or other applications intended to support or sustain life, or for any other application in which the failure of the Freescale Semiconductor product could create a situation where personal injury or death may occur. Should Buyer purchase or use Freescale Semiconductor products for any such unintended or unauthorized application, Buyer shall indemnify and hold Freescale Semiconductor and its officers, employees, subsidiaries, affiliates, and distributors harmless against all claims, costs, damages, and expenses, and reasonable attorney fees arising out of, directly or indirectly, any claim of personal injury or death associated with such unintended or unauthorized use, even if such claim alleges that Freescale Semiconductor was negligent regarding the design or manufacture of the part.

Freescale™ and the Freescale logo are trademarks of Freescale Semiconductor, Inc. All other product or service names are the property of their respective owners.

© Freescale Semiconductor, Inc. 2006. All rights reserved.

